

# SBC6000\_LVDS User Manual

Rev. 1.0

---

Release: 2011-10-24

## Revision record

Rev	Date	Description
1.0	2011-10-24	Initial version

Copyright: Embest info Technology Co., Ltd.. Reserves the right to interpret Non-written permission by the Company, any units and personality will be allowed to extract and copy all or part of this document does not in any form of communication.

Attention:

As the product version upgrades or other reasons, the contents of this document will be updated from time to time. Unless otherwise agreed, the use of this document only as a guide, all statements in this document, information and suggestions do not constitute any express or implied.

## Table Of Contents

<b>SBC6000_LVDS USER MANUAL .....</b>	<b>1</b>
1. SBC6000_LVDS OVERVIEW .....	4
2. SBC6000_LVDS INTERFACE SPECIFICATIONS .....	5
2.1 J2 (LVDS Signal) .....	5
2.2 J5 (Backlight1) .....	6
2.3 J7 (Backlight2) .....	6
2.4 J20 (Touch Signal) .....	6
2.5 J10 (TTL Signal) .....	7
3. THE WAY OF USING SBC6000_LVDS .....	7
<b>TECHNICAL SUPPORT AND WARRANTY SERVICE .....</b>	<b>10</b>
TECHNICAL SUPPORT SERVICE .....	10
MAINTENANCE SERVICE CLAUSE .....	10
BASE NOTICE TO PROTECT AND MAINTENANCE LCD .....	11
VALUE ADDED SERVICES .....	11

# 1. SBC6000\_LVDS Overview

The function of SBC6000\_LVDS Converter Board is transforming the TTL signals into LVDS signals. It can be used in SBC6000 and SBC6845, and is compatible with two specifications of LVDS LCD, respectively TM104SDH01 and TM104SDH03. Both the LCD screens are 10.4 inch and resolution of 800X600, the difference is the backlight power.

The detail of the SBC6000\_LVDS interfaces is shown in Table 1-1.

Table 1-1 Interface Details

Code	Interface	Remarks
J2	LVDS Signal	
J5	Backlight1, the backlight power, the output voltage is 12V.	For <b>TM104SDH03</b>
J7	Backlight2, the backlight power, the output voltage is 19V.	For <b>TM104SDH01</b>
J20	Touch Signal	
J10	TTL Signal	

The interfaces layout of the SBC6000\_LVDS is shown in Figure 1.1 and Figure 1.2.

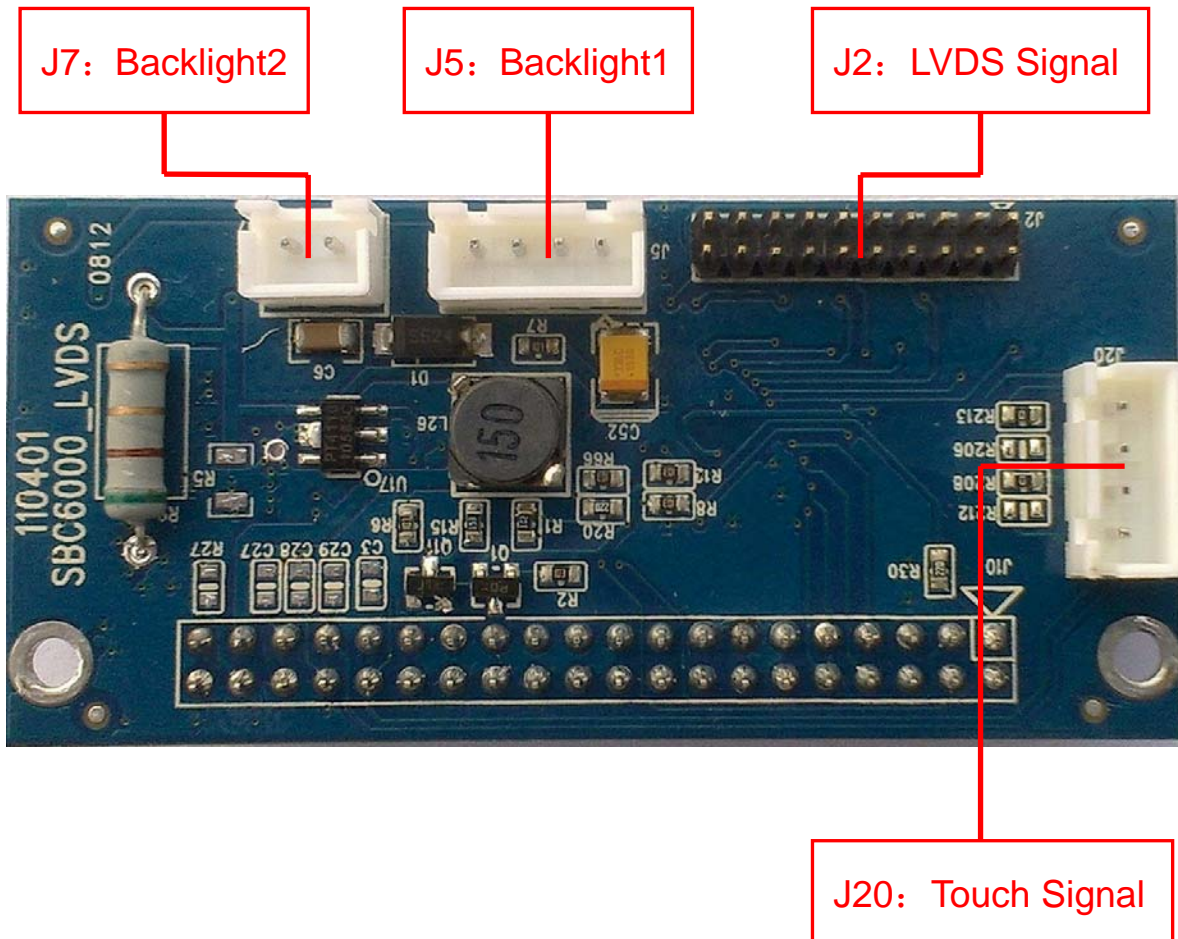

Figure 1.1 SBC6000\_LVDS Top Interface

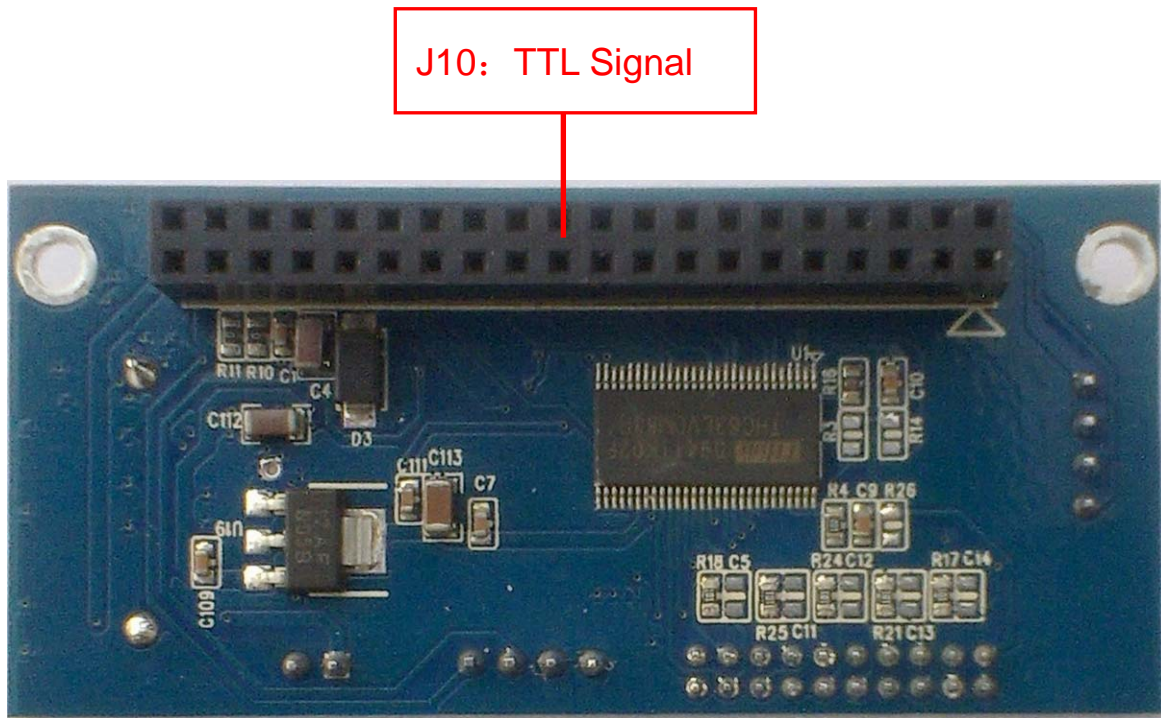

Figure 1.2 SBC6000\_LVDS Bottom Interface

## 2. SBC6000\_LVDS Interface Specifications

The detailed descriptions of the interface signal in SBC6000\_LVDS are shown as follows:

### 2.1 J2 (LVDS Signal)

J2 is the LVDS signal interface, which comes from the LVDS converter chip. Table 2-1 shows signal assignment of J2 interface.

Table 2-1 J2 Signal Assignment

Signal Name	Pin Number		Signal Name
VDD33V	1	2	VDD33V
GND	3	4	GND
TA-	5	6	TA+
GND	7	8	TB-
TB+	9	10	GND
TC-	11	12	TC+
GND	13	14	TCLK-
TCLK+	15	16	GND

TD-	17	18	TD+
NC	19	20	GND(1K)

## 2.2 J5 (Backlight1)

J5 is the backlight control signal of LCD, the output voltage is 12V, so J5 is used for TM104SDH03. Table 2-2 shows signal assignment of J5 interface.

Table 2-2 J5 Signal Assignment

Pin Number	Signal Name
1	12V
2	GND
3	ON_OFF
4	DIMMING

## 2.3 J7 (Backlight2)

J7 is the other backlight signal of LCD, the output voltage is 19V, so J7 is used for TM104SDH01. Table 2-3 shows signal assignment of J7 interface.

Table 2-3 J7 Signal Assignment

Pin Number	Signal Name
1	LEDK
2	LEDA

## 2.4 J20 (Touch Signal)

J20 is the touch signal of SBC6000\_LVDS, you can change the signal sequence by changing the location of resistance, shown in Figure 2.1, the default line sequence as shown in Table 2-4.

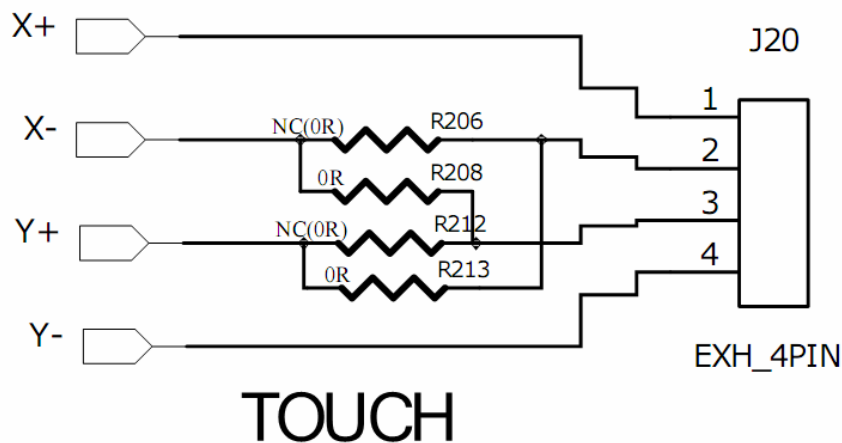

# TOUCH

Figure 2.1 Touch Signal

**Table 2-4 The Default Signal of Touch**

Pin Number	Signal Name
1	X+
2	Y+
3	X-
4	Y-

## 2.5 J10 (TTL Signal)

The TTL Signal is the input signal, which is converted into LVDS signal, and corresponds to the LCD signal U24 of SBC6845 board. Table 2-5 shows signal assignment of J10 interface.

**Table 2-5 J10 Signal Assignment**

Signal Name	Pin Number		Signal Name
GND	1	2	DCLK
HSYNC	3	4	VSYNC
GND	5	6	NC
R3	7	8	R4
R5	9	10	R6
R7	11	12	GND
G2	13	14	G3
G4	15	16	G5
G6	17	18	G7
GND	19	20	NC
B3	21	22	B4
B5	23	24	B6
B7	25	26	GND
LCDDEN	27	28	NC
NC	29	30	NC
NC	31	32	Y+
X-	33	34	Y-
X+	35	36	PWREN
+5V	37	38	DIMMING
+5V	39	40	+12V

## 3. The Way Of Using SBC6000\_LVDS

Using the custom data line that SBC6000\_LVDS supports, connect the LCD and SBC6000\_LVDS, and then connect the J10 of SBC6000\_LVDS and U24 of SBC6845, It is important that make sure the interface is pin to pin.

The way of connecting SBC6000\_LVDS and SBC6845 as shown in Figure 3.1.

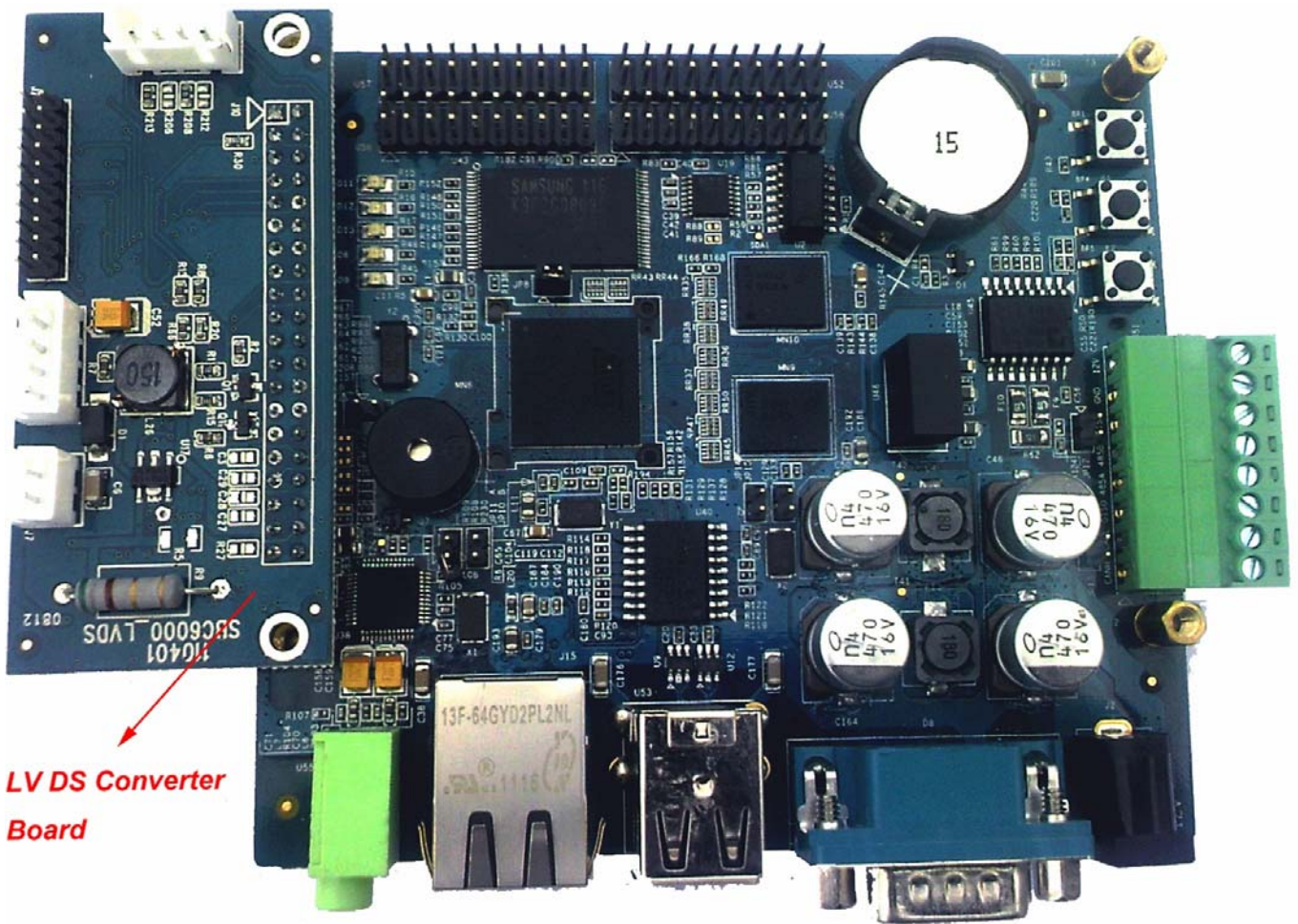

Figure 3.1 The way of connecting SBC6000\_LVDS and SBC6845

Connect the SBC6000\_LVDS and LCD using data line, and make sure the red line is connected to the first pin of J2, the way as shown in Figure 3.2.

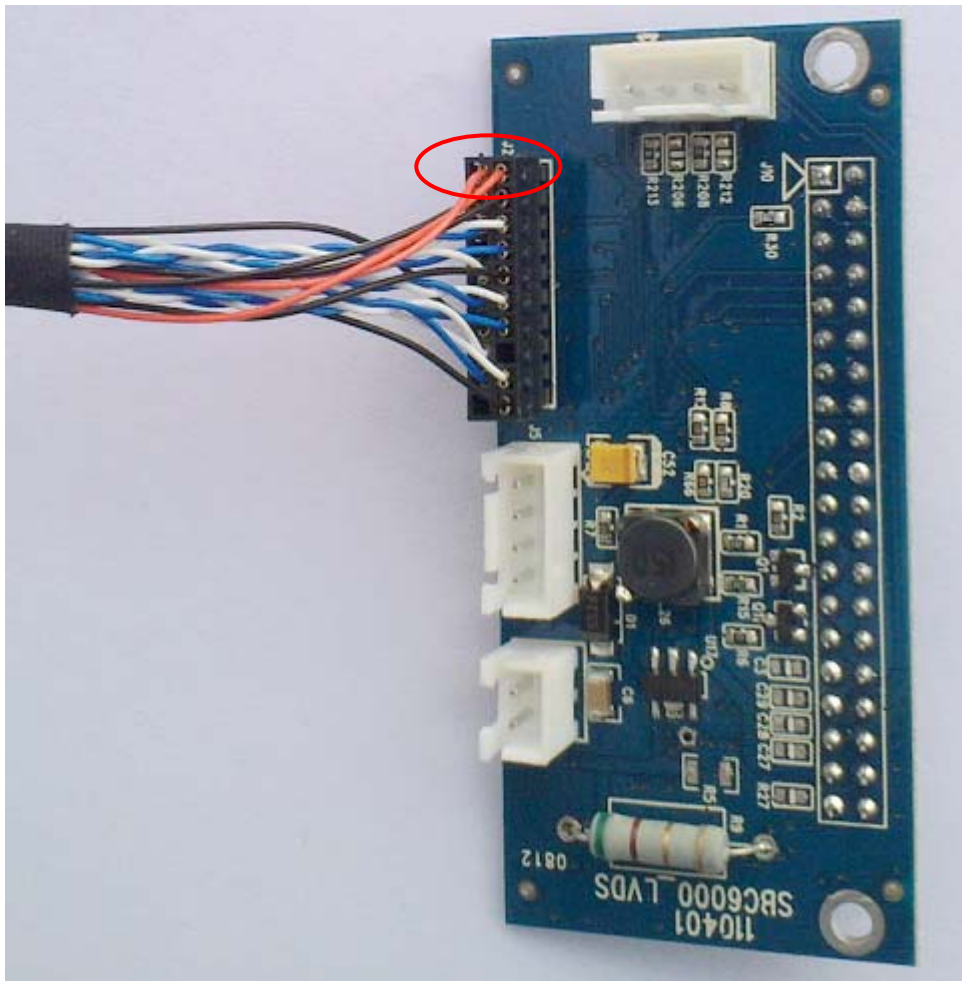

Figure 3.2 The Way of connecting SBC6000\_LVDS and LCD

When connect the hardware please note:

1. If the touch screen signal switched while connect. It is ok after recalibrate it.
2. The backlight of LCD is high voltage, and different types of LCD have different voltage supply, please take care and avoid damaging the LCD.
3. The LCD has Anti-error design, when connect please make attention, do not insert it by force.

# Technical support and Warranty Service

## Technical support service

---

Embest provide one year free technical support service for all products Embest is selling. Technical support service covers:

- Embest embedded platform products software/hardware materials
- Assist customers compile and run the source code we offered
- Solve the problems accurate on embed software/hardware platform if user was following the instruction in the documentary we offered
- Judge if the product failure is existing

Special explanation, the situations listed below have NOT been included in the range of our free technical support service, Embest will handle the situation with discretion:

- Software/Hardware issues user met during the self-develop process
- Issues happened when users compile/run the embedded OS which was tailored by users themselves
- User's own application
- Problems happened during the modification of our software source code

## Maintenance service clause

---

The product, which was used properly, will take the warranty since the day of the sale:

PCB: Provide 12 months free maintenance service

1. The situations listed below have NOT been included in the range of our free maintenance service, Embest will charge the service fee with discretion:
  - A. Can't provide valid Proof-of-Purchase, the identification label was torn up or illegible, the identification label was altered or not accord with the actual products;
  - B. Didn't follow the instruction of the manual in order to damage the product
  - C. Due to the natural disasters (unexpected matters), or natural attrition of the components, or unexpected matters leads the defects of appearance/function;
  - D. Due to the power supply, bump, leaking of the roof, pets, moist, impurities into the boards, all those reasons which lead the defects of appearance/function;

- E. User unauthorized weld or dismantle parts leads the product's bad condition, or let other people or institution which was not authorized by Embest to dismantle, repair, change the product leads the product bad connection or defects of appearance/function;
  - F. User unauthorized install the software, system or incorrect configuration or computer virus leads the defects;
  - G. Purchase the products through unauthorized channel;
  - H. Those commitment which was committed by other institutions should be responsible by the institutions, Embest has nothing to do with that;
2. During the warranty period, the deliver fee which delivery to Embest should be covered by user, Embest will pay for the return delivery fee to user when the product was repaired. If the warranty period is expired, all the deliver fees will be charged by users.
  3. When the boards needs repair, please contact technical support department.

Note: If the product is returned without the permission of our technician, we will not take any responsibility for them.

## Base notice to protect and maintenance LCD

---

1. Do not use finger nails or hard sharp object to touch the surface of the LCD, otherwise user can't enjoy the above service
2. Embest recommend user to purchase a piece of special wiper to wipe the LCD after long time use , please avoid clean the surface with fingers or hands to leave fingerprint
3. Do not clean the surface of the screen with chemicals, otherwise user can not enjoy above service.

## Value Added Services

---

We will provide following value added services:

- Provided services of driver develop base on Embest embedded platform, like serial port, USB interface devices, LCD screen.
- Provided the services of control system transplant, BSP drivers develop, API software developing.
- Other value added services like power adapter, LCD parts.
- Other OEM/ODM services.
- Technically training.

Please connect Embest and get technical support:

- Support Tel: +86-755-25503401
- Fax: +86-755-25616057
- Pre-Sale consultation: [market@embedinfo.com](mailto:market@embedinfo.com)
- After-Sale consultation: [support@embedinfo.com](mailto:support@embedinfo.com)